

## GESTRA Steam Systems

# GESTRA Information A 1.3

## Waterhammer and how to avoid it

The effect of sudden pressure changes (pressure shocks) in pipelines or other equipment is generally known as waterhammer. The stress caused by such a pressure shock is very often far higher than that to which the equipment is normally subjected. The shock wave, which travels with the velocity of sound, can cause deformation or even breakage of equipment. Waterhammer is recognized by violent noises.

There are two types of waterhammer:

1. Hydraulic waterhammer in installations with cold liquids;
2. Thermal waterhammer in steam/condensate plants and in hot water systems.

In installations carrying hot liquids both types of waterhammer can occur.

### Origin of hydraulic waterhammer

If a pipeline is shut by a rapid-closing valve, the movement of the head of liquid upstream of the shut-off valve is stopped suddenly. The inertia force produces a pressure shock. As liquids are almost incompressible, this shock propagates into all directions.

Just downstream of the shut-off valve the flow does not cease instantaneously, and a vacuum is formed. The liquid is therefore drawn back and rebounds against the shut-off valve and creates a pressure wave. This wave travels to and fro, gradually decreasing in strength.

### Origin of thermal waterhammer

Thermal waterhammer occurs when steam bubbles entrained by the condensate or formed by flashing enter a line filled with condensate at a lower temperature. The steam bubbles collapse abruptly and a vacuum is formed. Immediately from all sides the surrounding condensate flows in and collides (implosion).

This waterhammer is in the first instance caused by:

- a) Incorrect installation of valves and equipment and improper laying of pipelines;
- b) unqualified handling of the valves;
- c) unsuitable or wrong-sized equipment;
- d) faulty equipment.

The intensity of the waterhammer depends on the extent of the contact surface between steam and water, the velocity of the steam and/or the water and the temperature difference between water and steam.

Waterhammer can also occur in inadequately drained steam lines. Water flows with a considerably lower velocity than steam. If the water is accelerated by the steam and then hits a resistance, a sudden pressure increase results resembling the collision of two heads of water when filling a vacuum created by condensation. This waterhammer is rather dangerous as can be seen from the erosion it causes, and is well known on turbine blades.

A sudden shifting of trapped air or gas pockets, e.g. in pipelines, can cause another type of waterhammer.

### Measures to be taken against waterhammer

Pressure shocks forming after sudden shutting-off of pipelines carrying liquids can be calculated or determined by graphical methods. It is possible to allow for the influence of frictional forces and the moduli of elasticity of the liquid and the materials used. These pressure shocks can be absorbed by correct sizing of valves and pipelines. They can be diminished by installation of so called damping vessels, as used downstream of plunger pumps.

Pressure shocks resulting from thermal waterhammer cannot be calculated exactly. This has to be taken into account when designing and operating a plant. Waterhammer can only be avoided if a plant is properly sized and laid out and competently operated. The ideal is to build a plant such that waterhammer cannot occur. If this is impossible to achieve, equipment providing effective damping has to be used.

The following are examples taken from practice.

Figures **a**) show installations where waterhammer can occur.

Figures **b**) give suggestions on improvement to avoid or dampen waterhammer.

**Fig. 1**

**How to avoid waterhammer in steam lines**

- a) If the stop valve is closed the remaining steam in the line will condense. The condensate collects in the lower part of the line and cools down. If the valve is reopened the inflowing steam meets the cold condensate. The result is waterhammer.
- b) If the run of the pipe cannot be altered, the line, even if it is relatively short, should be drained through a trap. Long steam lines should be trapped at regular intervals, and always before the line rises. All steam lines should be trapped at the end.

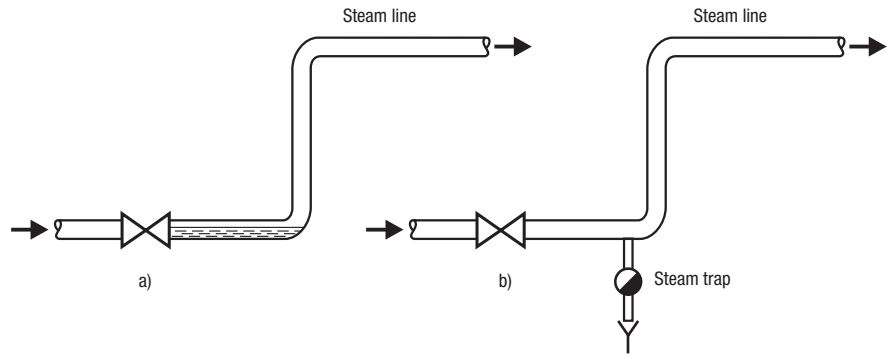
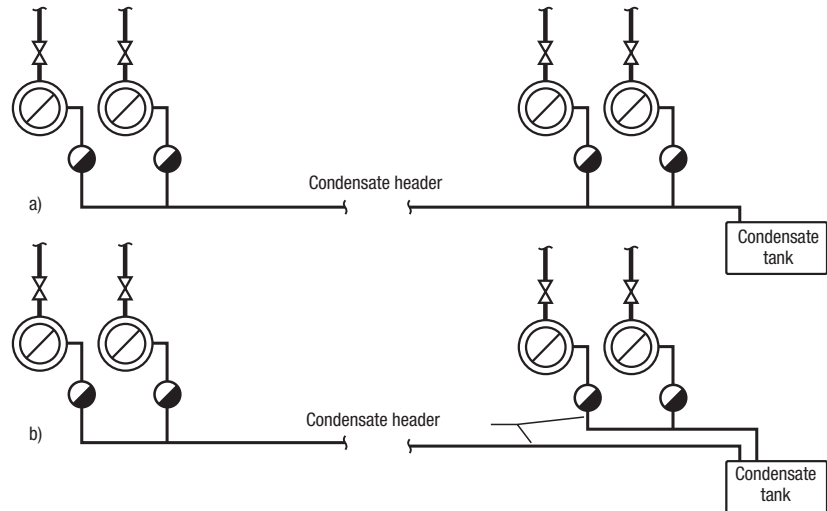

**Fig. 1**

**Fig. 2**

**How to avoid waterhammer in condensate lines**

- a) The condensate from the heat exchangers at the far end cools down rapidly on its way to the condensate tank. The condensate with the flash steam from the heat exchangers which are closer to the condensate tank mixes with this cold condensate. The flash steam condenses abruptly and waterhammer will result.
- b) Waterhammer will be avoided if the condensate is sent to the condensate tank via separate headers. Condensate from heat exchangers having different pressures should also be fed to the condensate tank by separate headers.

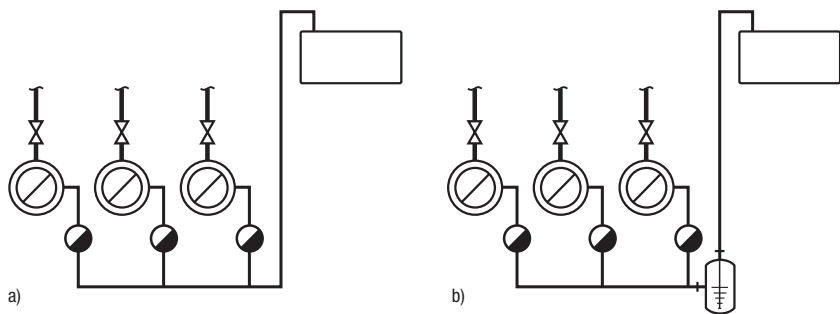

**Fig. 2**

**Fig. 3**

**How to dampen waterhammer if condensate is lifted**

- a) Waterhammer easily occurs if the condensate is lifted. In this case it is almost impossible to avoid it completely.
- b) The remedy is the installation of a damping pot which by its cushioning action neutralizes the waterhammer. Despite the ascending pipeline, the condensate is properly discharged, without any noise.



**Fig. 3**

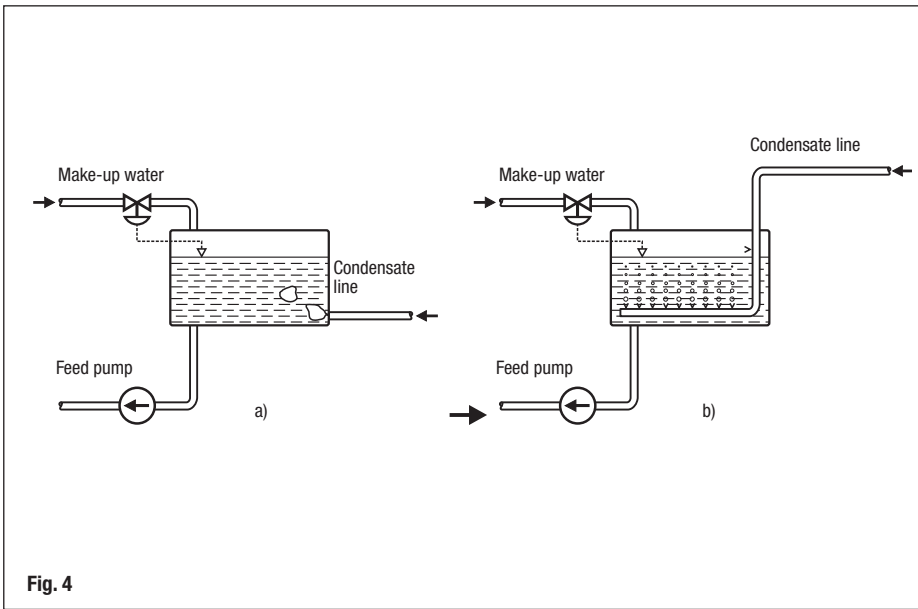

**Fig. 4**  
**How to avoid waterhammer when feeding condensate into feed water tanks**

a) Normally flash steam is formed downstream of a steam trap. To avoid wasting it, the condensate with the flash steam can be fed into the tank below water level. Here, however, the flash steam comes into contact with relatively cold water.

When the condensate enters the tank large steam bubbles are formed which condense abruptly. The result is waterhammer accompanied by loud noises.

If the heat exchangers are shut down water may flow back into the condensate line. The danger of waterhammer in the line during start-up is considerable.

b) The manifold small nozzles in the tube on the bottom of the tank will prevent the formation of large steam bubbles. Perceptible waterhammer and noises are thus avoided.

The introduction of the condensate line into the tank from above and the small bore just above the level normally preclude the backflow of the condensate if the heat exchanger is shut down.

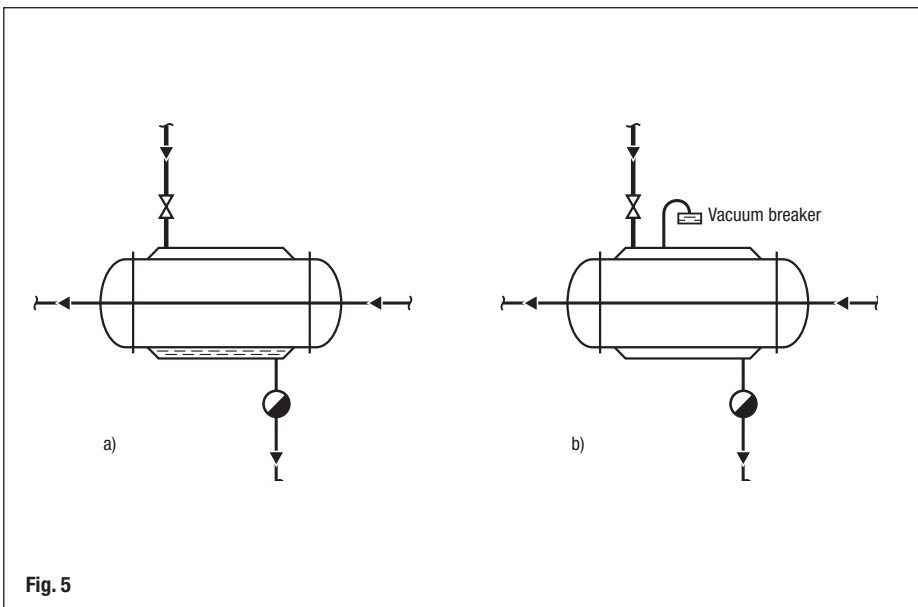
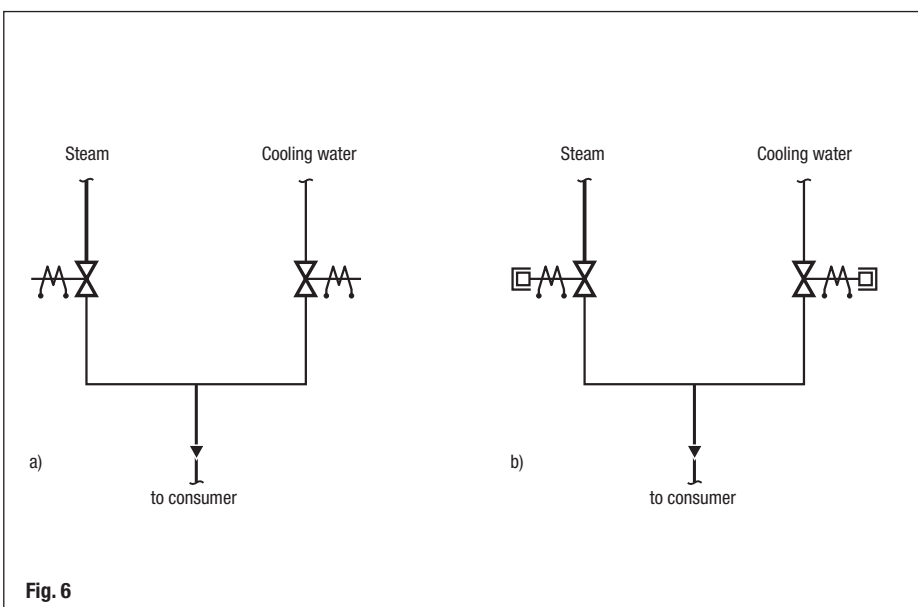

**Fig. 5**  
**How to avoid waterhammer in heat exchangers where condensate collects by the formation of vacuum**

a) If the steam plant is shut down a vacuum is formed as the remaining steam condenses. The risk is then incurred that condensate is sucked back into the heat exchanger or that the condensate is not completely discharged from the heating surface (not to mention the risk of permanent deformation of the heat exchanger).

If the plant is restarted, the steam flows across the water surface, condenses abruptly and causes waterhammer.

b) The installation of a Disco non-return valve as a vacuum breaker prevents the formation of vacuum. The condensate cannot be sucked back and the remaining condensate will flow off. Waterhammer is therefore avoided.



**Fig. 6**  
**How to reduce waterhammer in plants used for heating and cooling processes**

a) If one switches from cooling to heating or vice versa, the rapid opening or closing of the solenoid valves can cause hydraulic and thermal waterhammer.

b) Waterhammer can be avoided if the valves are opened and closed slowly. It is recommended to use either solenoid valves with hydraulic damping devices or motorized valves.

Fig. 7

**How to avoid waterhammer in horizontal heat exchangers controlled from the steam side**

a) Waterhammer can occur because condensate banks up into the heating coils, in particular at low load conditions. The steam flows with a relatively high velocity across the water surface. This leads to the formation of steam bubbles which condense abruptly in the cold condensate.

Banking-up of condensate into the heating surface can be caused by:

- Steam trap with wrong working principle.
- Steam trap too small or defective.
- Differential pressure available for steam trap too low, e.g. condensate lifted downstream of steam trap or pressure in condensate header to high.
- Steam pressure in the heating surface too low, e.g. heating surface too large.
- Pressure drop in the heating surface too high at low load conditions. The pressure drop increases the more the control valve on the steam side is throttled. If the temperature of the liquid to be heated is below 100 °C vacuum may be formed in the heating surface (negative pressure drop for the steam trap). Condensate discharge is no longer possible. On the contrary, condensate might even be sucked back into the heat exchanger.

b) To avoid waterhammer it is essential to ensure that the condensate is completely discharged from the heating surface at all load conditions.

This may be achieved in the following ways:

1. Use ball float traps with automatic air-venting capacity for steam trapping. All other steam trap systems do not react fast enough to changed operating conditions.
2. Check steam trap for correct size or damage.
3. Maintain minimum pressure in heating surface by using a control valve that does not throttle too much.
4. Decrease load fluctuations.
5. Reduce back pressure, if possible, provide free drainage.
6. Install steam trap at a lower point so that condensate is freely discharged downwards and an additional pressure head available.
7. Use longer and larger pipeline upstream of steam trap so that condensate can be discharged if the control valve is throttled.
8. If installation as per point 7 is not possible mount a collecting pot upstream of steam trap.
9. Prevent the formation of vacuum by installing a vacuum breaker valve.
10. Prevent condensate from being sucked back into the heating surface by installing a non-return valve downstream of heat exchanger.
11. Use heat exchanger with smaller heating surface and increase steam pressure to compensate.

If all these measures cannot eliminate waterhammer there is only one solution left

12. Use a vertical heat exchanger.

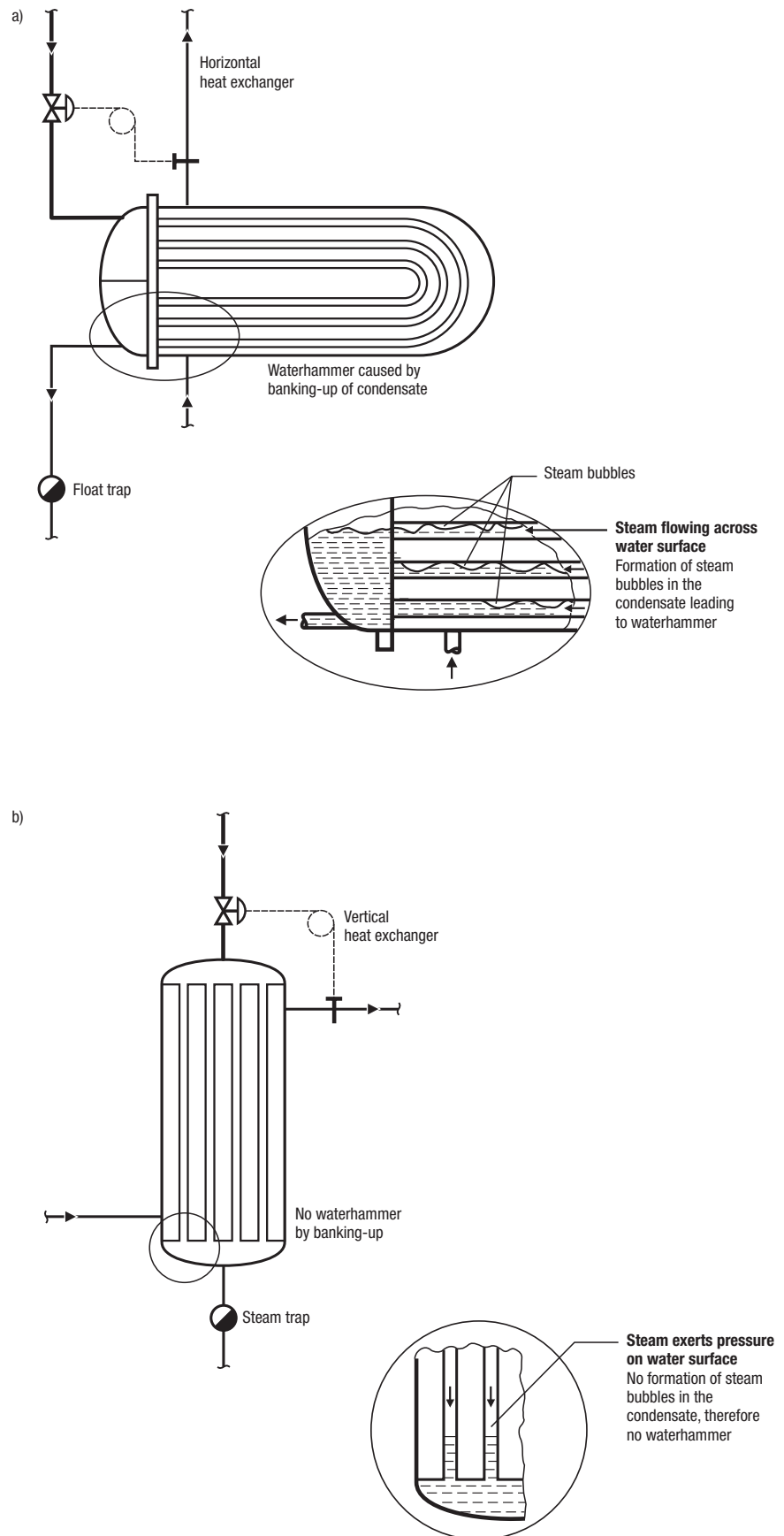

Fig. 7

**GESTRA AG**

P. O. Box 10 54 60, D-28054 Bremen  
 Münchener Str. 77, D-28215 Bremen  
 Telephone +49 (0) 421 35 03 - 0, Fax +49 (0) 421 35 03-393  
 E-Mail gestra.ag@flowserve.com, Internet www.gestra.de



GESTRA